

National Aeronautics and
Space Administration

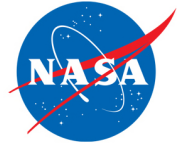

TECHNOLOGY SOLUTION

Mechanical and Fluid Systems

Quick Disconnect for High Pressure Mate/De-Mate

[Unique Dual-Poppet Quick Disconnect Removes Dust Prior to Mating](#)

NASA Kennedy Space Center seeks partners interested in the commercial application of the Quick Disconnect for High Pressure Mate/De-Mate. NASA's Kennedy Space Center (KSC) is offering companies licensing and partnering opportunities for the development and commercialization of this innovative technology. Designed at KSC, this technology is intended for use in dusty environments where dust particles can contaminate high pressure connectors resulting in wear on connector surfaces and unreliable connections. The Quick Disconnect (QD) utilizes the gas supplied by the umbilical to spray on, entrain, and remove dust from the connector surfaces prior to mating.

BENEFITS

- Safety - maintaining cleanliness of umbilical connectors helps ensure high pressure connections are reliable, complete, and secure.
- Maintainability - extends connector life by reducing wear and tear on connector surfaces and gaskets caused by dust and debris.
- Cost Savings - clean connectors help reduce gas/fluid loss caused by leakage.

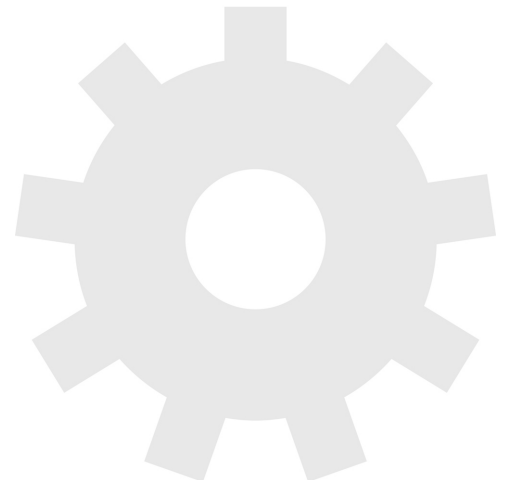

THE TECHNOLOGY

Dusty, dirty environments can be very tough on connectors. The abrasive nature of dust and dirt particles can rub and wear down connector surfaces through friction, and have a negative effect on coatings used on gaskets to seal equipment. Dust on umbilical connections can also make mating and de-mating electrical and fluid connections difficult, hazardous, and unreliable. NASA's Quick Disconnect (QD) design uses the gas supplied by the umbilical to spray the connector surfaces prior to mating to remove dust and debris. The QD uses a novel dual-poppet design and springs that balance forces on umbilical components. This allows a controlled release of gas to clear away dust from the end of the connector before it is inserted in the supply umbilical. The connector assembly is capable of mating and de-mating under 3500 psi fluid/gas. One poppet seals the QD while de-mated and automatically cleans the front surface of the QD during mating. A second poppet seals the QD while de-mated and automatically cleans the cylindrical surface of the QD during mating. The internal cavity of the QD is specifically designed such that the pressure in the line is reduced from 3500 psi to 450 psi while surface cleaning occurs. Finally, all exterior connector surfaces are designed to minimize the entrapment of dust while in the de-mated position.

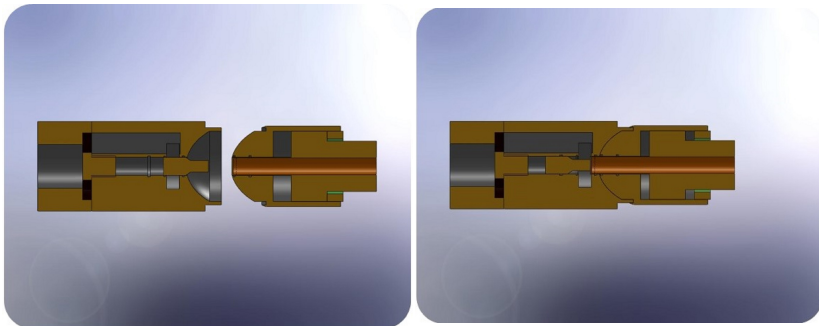

Quick Disconnect Unmated

Quick Disconnect Mated

APPLICATIONS

The technology has several potential applications:

- Oil and Gas Drilling
- Oil and Gas Installation, Repair, and Maintenance
- Commercial Space Applications
 - Breathing Air
 - Electrical/Fluid Transfers

PUBLICATIONS

Patent No: 9,647,379

technology.nasa.gov

More Information

National Aeronautics and Space Administration

Agency Licensing Concierge

Kennedy Space Center

MS LASSO-012

Kennedy Space Center, FI 32899

202-358-7432

Agency-Patent-Licensing@mail.nasa.gov

www.nasa.gov

NP-2015-02-1359-HQ

NASA's Technology Transfer Program pursues the widest possible applications of agency technology to benefit US citizens. Through partnerships and licensing agreements with industry, the program ensures that NASA's investments in pioneering research find secondary uses that benefit the economy, create jobs, and improve quality of life.

KSC-13465, KSC-13492-DIV1, KSC-TOPS-63