

TECHNOLOGY SOLUTION

Manufacturing

Lunar Landing Pads

Durable takeoff and landing pads for the Moon and beyond

Lunar landing and launch pads represent critical infrastructure for enabling a sustained presence on the Moon or other planetary bodies. Such a Moon presence would require repeated lunar landings and takeoffs, preferably near an outpost or habitat. In the absence of takeoff and landing pads, such vehicles could project lunar regolith at high velocities, “sandblasting” the surrounding infrastructure and causing damage.

Conventional paver technology does not have the capability to withstand the loads experienced by landing pads during vehicle landing or take off. Use of existing technology may result in pavers being displaced by the plume of the vehicle, or exhaust from the vehicle entering spaces between paver seams and eroding the regolith underneath the landing pad. To address this issue, engineers at NASA's Kennedy Space Center and Sidus Space developed a novel interlocking paver system enabling the robotic construction of high stability vertical takeoff and landing pads.

BENEFITS

- **Enhanced stability & longevity:** The interlocking design of the pavers provides a secure connection, reducing the risk of displacement during vehicle landings and takeoffs.
- **Prevents regolith erosion:** The interlocking pavers prevent exhaust gases from entering the spaces between paver seams, mitigating erosion and projection of underlying regolith onto surrounding infrastructure.
- **In-situ resource utilization:** The ability to construct the pavers from in situ materials, such as lunar regolith, reduces the need for transporting materials from Earth to extraterrestrial surfaces.
- **Scalability:** The interlocking paver system can be easily expanded or reconfigured to accommodate different landing pad sizes or layouts.
- **Autonomous installation:** The pavers can be installed by an autonomous paver-laying machine, reducing the need for human intervention in harsh environments.

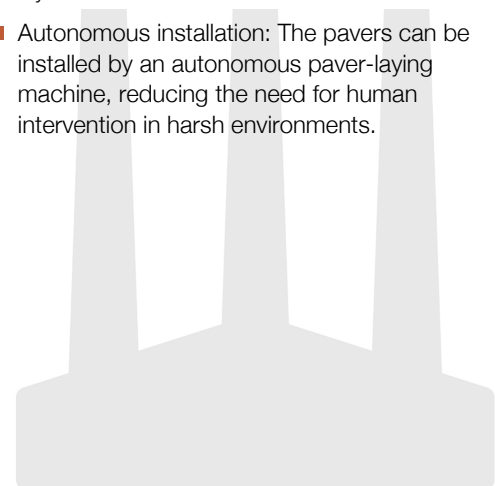

THE TECHNOLOGY

The jointly developed interlocking paver design consists of a molded solid material with tapered interlocking features that interface with features of an opposite gender in three orthogonal directions. This establishes a tolerated connection between the pavers that locks down six degrees of freedom.

More specifically, the system consists of two types of pavers: polygon and spacer pavers. Both are symmetrical about the longitudinal and transverse axes and are designed to interlock securely with one another in a checkerboard pattern. The polygon paver features an octagonal top level and a rectangular bottom level with protrusions and recessed notches. The spacer paver has an elongated center portion with isosceles trapezoid extensions on the top level and a rectangular bottom level with protrusions and notches. The interlocking design locks down six degrees of freedom, providing enhanced stability and preventing the flow of exhaust gases between the seams to mitigate erosion of the underlying regolith.

The pavers could be constructed leveraging in-situ resource utilization (ISRU). Lunar regolith has been identified as a potential construction material. Additionally, the pavers could be installed via robotic assembly, reducing the need for human labor in harsh environments.

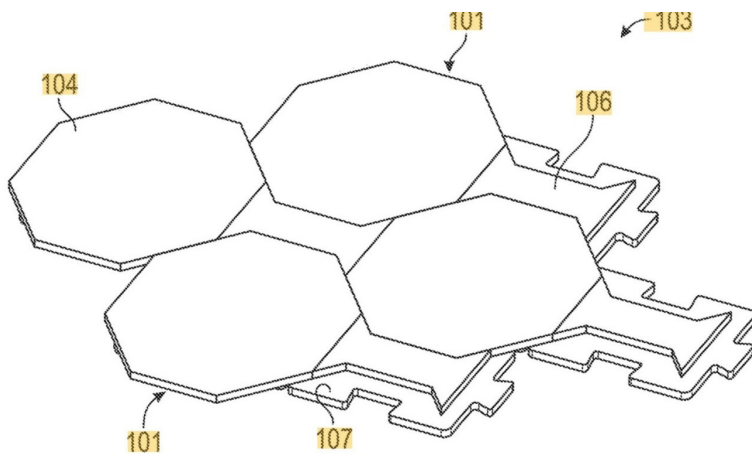

A top perspective drawing of the patented vertical takeoff and landing pad constructed using the jointly developed interlocking pavers.

APPLICATIONS

The technology has several potential applications:

- Extraterrestrial landing/takeoff pads: Construction of stable landing pads for spacecraft on surfaces like the Moon, Mars, or other planetary bodies.
- Consumer & commercial applications: The pavers could be used to provide easy installation for consumer and commercial applications (e.g., driveways, walkways, streets, patios, etc.) by requiring less site prep work, as well as potentially last longer than current paver technologies.
- Military landing/takeoff pads: Special military situations may benefit from this design in atypical environments.

PUBLICATIONS

Patent No: 10,920,377

technology.nasa.gov

National Aeronautics and Space Administration

Agency Licensing Concierge

Kennedy Space Center

MS LASSO-012

Kennedy Space Center, FI 32899

202-358-7432

Agency-Patent-Licensing@mail.nasa.gov

www.nasa.gov

NP-2015-02-1377-HQ

NASA's Technology Transfer Program pursues the widest possible applications of agency technology to benefit US citizens. Through partnerships and licensing agreements with industry, the program ensures that NASA's investments in pioneering research find secondary uses that benefit the economy, create jobs, and improve quality of life.

KSC-14035, KSC-TOPS-89